

UNITA' ASPIRANTI TRIFASE / THREE-PHASE SUCTION UNITS



CTS

UTS

MODELLO / MODEL	UTS 085	UTS 130	UTS 160	UTS 220	UTS 300	UTS 400	UTS 550	UTS 750	UTS 110
Alimentazione (V-Hz) Power supply (V-Hz)	400 – 50/60								
Potenza motore (kW) Motor power (kW)	0.85	1.3	1.6	2.2	3	4	5.5	7.5	11
Produzione oraria max (kg/h)* Max throughput (kg/h)*	220	320	360	460	520	630	1090	1530	2540
Depressione statica (mbar) Static depression (mbar)	160	190	210	240	270	440	440	440	440
Rumorosità massima (dBA) Noise max level (dBA)	< 80								
Peso approssimativo (kg) Approx. Weight (kg)	30	32	35	40	45	68	94	130	290

* Materiale con p.s.a.: 0,65 kg/dm³ - Distanza verticale: 4m - Distanza orizzontale: 5m / Material with bulk density.: 0,65 kg/dm³ - Vertical distance: 4m – Horizontal distance: 5m

CARICATORI TRIFASE / THREE-PHASE LOADERS

MODELLO / MODEL	CTS 2	CTS 4	CTS 6	CTS 10	CTS 14	CTS 20	CTS 30	CTS 50	CTS 80	CTS 110
Capacità (dm ³) Capacity (dm ³)	2	4	6	10	14	20	30	50	80	110
Peso (kg) Weight (kg)	6	8	12	13	15	18	19	22	26	40

UNITA' FILTRANTI / FILTERS UNIT

MODELLO / MODEL	UFS 50	UFS 100	UFS 200	UFS 300	UFS 400
Materiale filtro Filter material	Cellulosa Cellulose	Cellulosa Cellulose	Cellulosa Cellulose	Cellulosa Cellulose	Cellulosa Cellulose
Grado di filtrazione (μ) Filtering grade (μ)	2	2	2	2	2

UNITA' ASPIRANTI TRIFASE / THREE-PHASE SUCTION UNITS

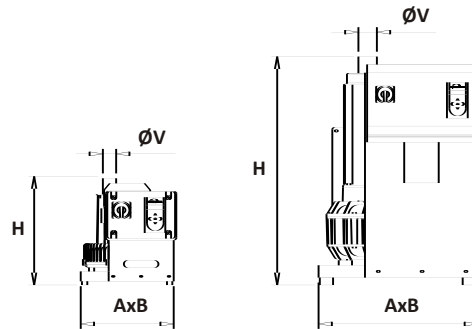

UTS 400-550-750-110

DIMENSIONI (mm) / DIMENSIONS (mm)

MODELLO / MODEL	UTS 085	UTS 130	UTS 160	UTS 220	UTS 300	UTS 400	UTS 550	UTS 750	UTS 110
A	425	425	425	425	425	600	600	600	600
B	350	350	350	350	350	725	725	725	725
H	375	400	430	460	470	850	880	920	950
ØV	40	40-50	40-50	50	50	50-60	60	60-70	60-70

CARICATORI TRIFASE / THREE-PHASE LOADERS

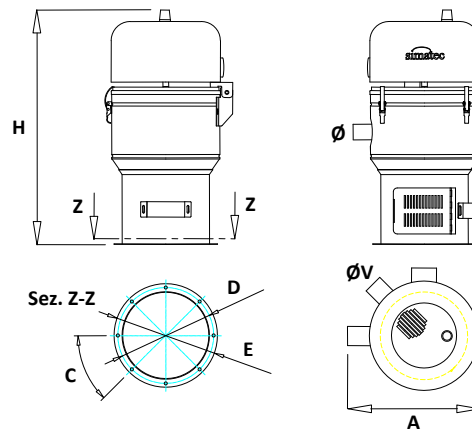

CTS 2-4

DIMENSIONI (mm) / DIMENSIONS (mm)

MODELLO / MODEL	CTS 2	CTS 4	CTS 6	CTS 10	CTS 14	CTS 20	CTS 30	CTS 50	CTS 80	CTS 110
A	222	222	332	332	332	332	332	555	555	555
H	470	615	615	645	685	780	940	830	1010	1190
Ø	40-50-60	40-50-60	40-50-60	40-50-60	40-50-60	40-50-60	40-50-60	50-60-70	50-60-70	50-60-70
ØV	40-50-60	40-50-60	40-50-60	40-50-60	40-50-60	40-50-60	40-50-60	50-60-70	50-60-70	50-60-70
C	45°	45°	45°	45°	45°	45°	45°	45°	45°	45°
D	180	180	250	250	250	250	250	370	370	370
E	200	200	270	270	270	270	270	390	390	390

UNITA' FILTRANTI / FILTERS UNIT

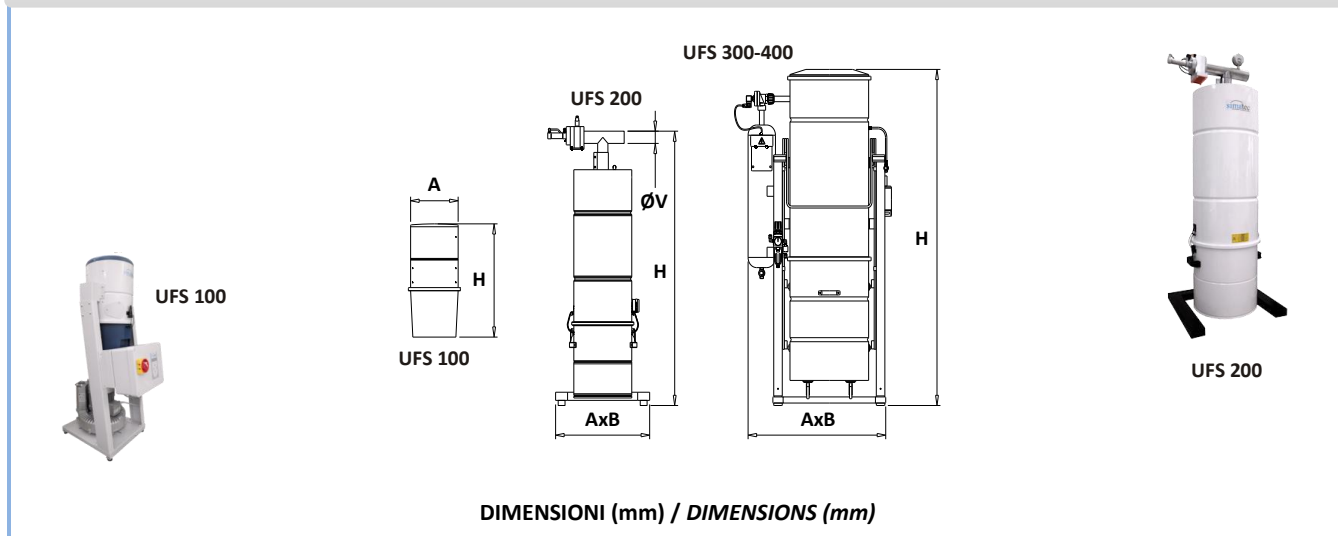

MODELLO / MODEL	UFS 50	UFS 100	UFS 200	UFS 300	UFS 400
A	Ø230	Ø300	600	830	950
B	-	-	600	830	950
H	350	560	1360	1670	1670
ØV	40-50	40-50	40-50-60	50-60-70	60-70

ABBINAMENTI CONSIGLIATI / RECOMMENDED COMBINATIONS

MODELLO / MODEL	UTS 085	UTS 130	UTS 160	UTS 220	UTS 300	UTS 400	UTS 550	UTS 750	UTS 110
CTS 2	✓								
CTS 4	✓								
CTS 6	✓	✓	✓						
CTS 10	✓	✓	✓						
CTS 14		✓	✓	✓					
CTS 20			✓	✓	✓	✓			
CTS 30			✓	✓	✓	✓			
CTS 50					✓	✓	✓	✓	
CTS 80						✓	✓	✓	✓
CTS 110							✓	✓	✓
FILTRI / FILTERS:									
UFS 50	✓	✓							
UFS 100		✓	✓	✓	✓				
UFS 200				✓	✓	✓			
UFS 300						✓	✓	✓	✓
UFS 400							✓	✓	✓